

Field of application

When equipping forming presses with hydraulic or hydro-mechanical clamp units, Optima hydraulic units provide the necessary operating pressure. Due to their compact design, the units are particularly suitable for retrofitting existing machines.

The types HAK 400 and HAM 400 support the operation of **hydraulic** clamp units.

Mode of operation

A submerged motor driven geared pump unit drives a radial piston pump which supplies the necessary operating pressure of 400 bars. This operating pressure is required to apply and maintain the clamping force. The operating pressure is controlled by a switch which maintains the pressure by reactivating the oil pump.

Features

What makes Optima hydraulic units remarkable is the maximum range of services contained within a minimum space.

Due to their modular design, these units may be adapted to the various requirements, starting with the basic unit. The components used, which are series produced by well-known manufacturers, guarantee the reliability of the units.

Basic equipment

- replaceable filter cartridge
- pressure switch
- pressure control valve
- mounting bracket
- pressure gauge
- electrical temperature and level control
- pressure reservoir
- non-return valve

The company reserves the right to make technical changes!

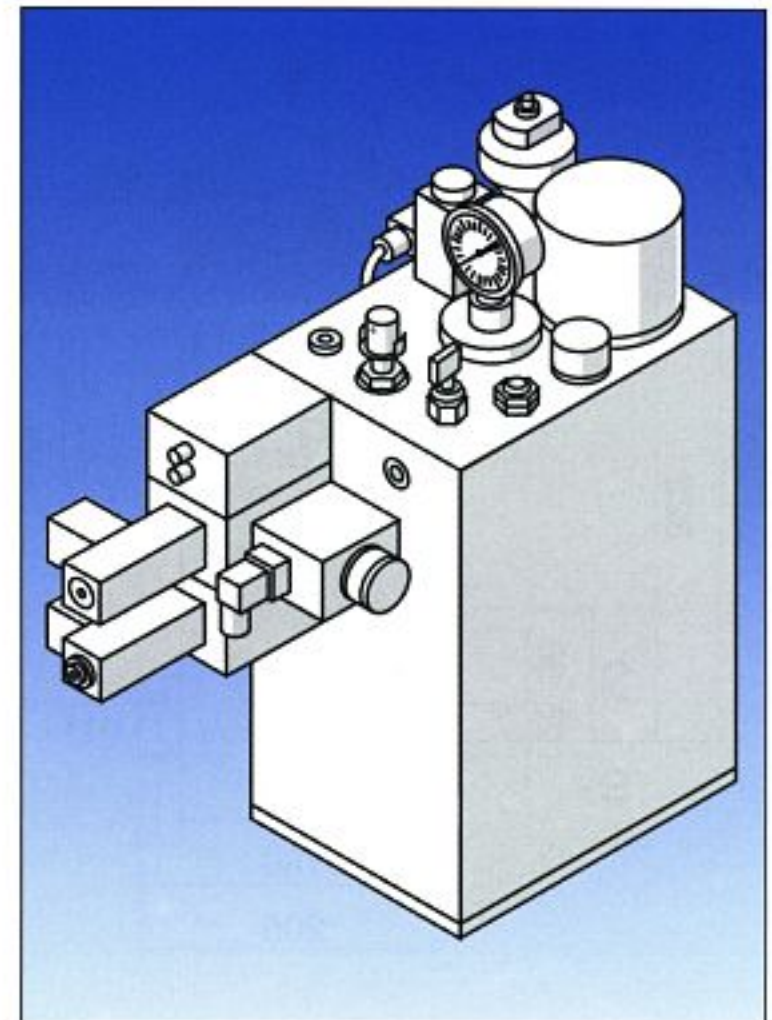

Advantages

- compact design
- silent operation
- modular structure – expansion possible later
- problem-free integration into the existing system
- quick and easy to install
- may be installed in an upright or suspended position

Installation

The individual housing components are manufactured from aluminium.

The unit may be mounted either on the outside of the press or on a horizontal surface (e.g. on the floor) with in each case a special bracket (the wall bracket and rails for attaching it to the floor are included in delivery).

Basic unit with up to 400 bars of operating pressure

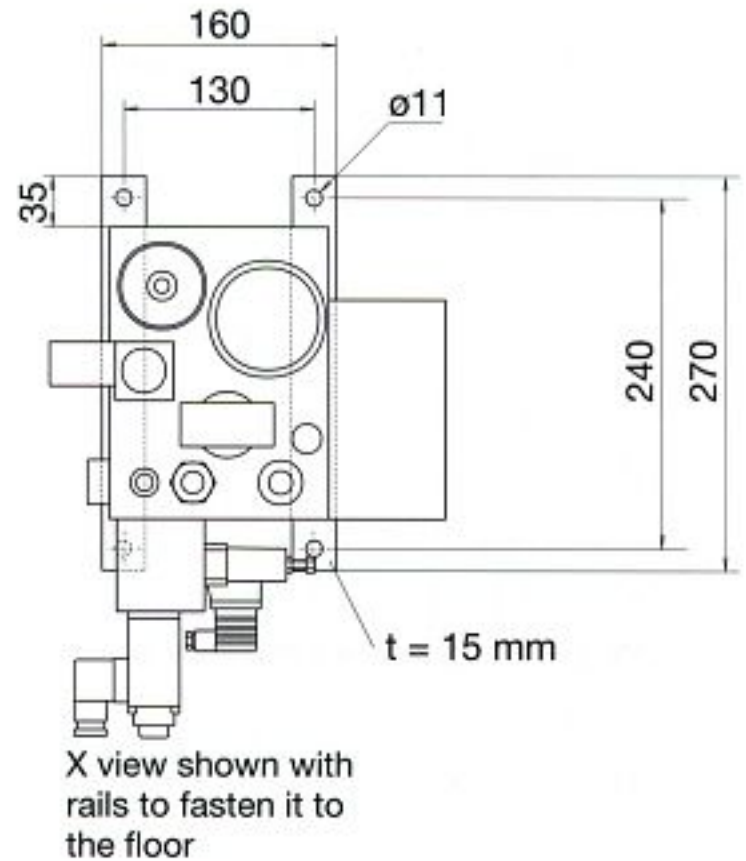
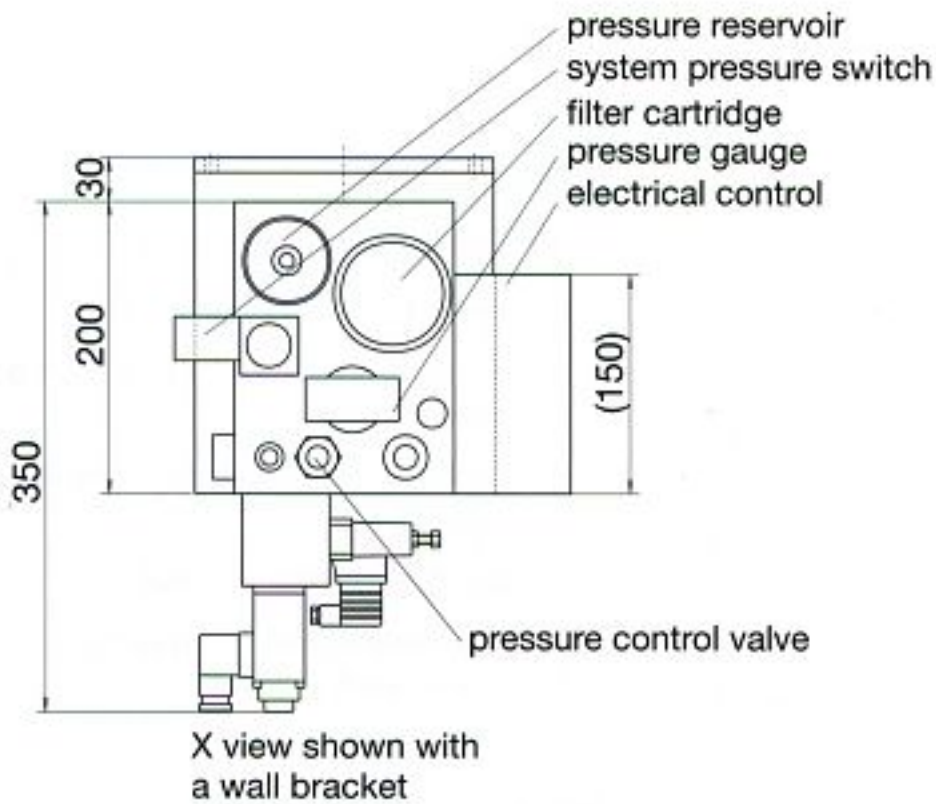
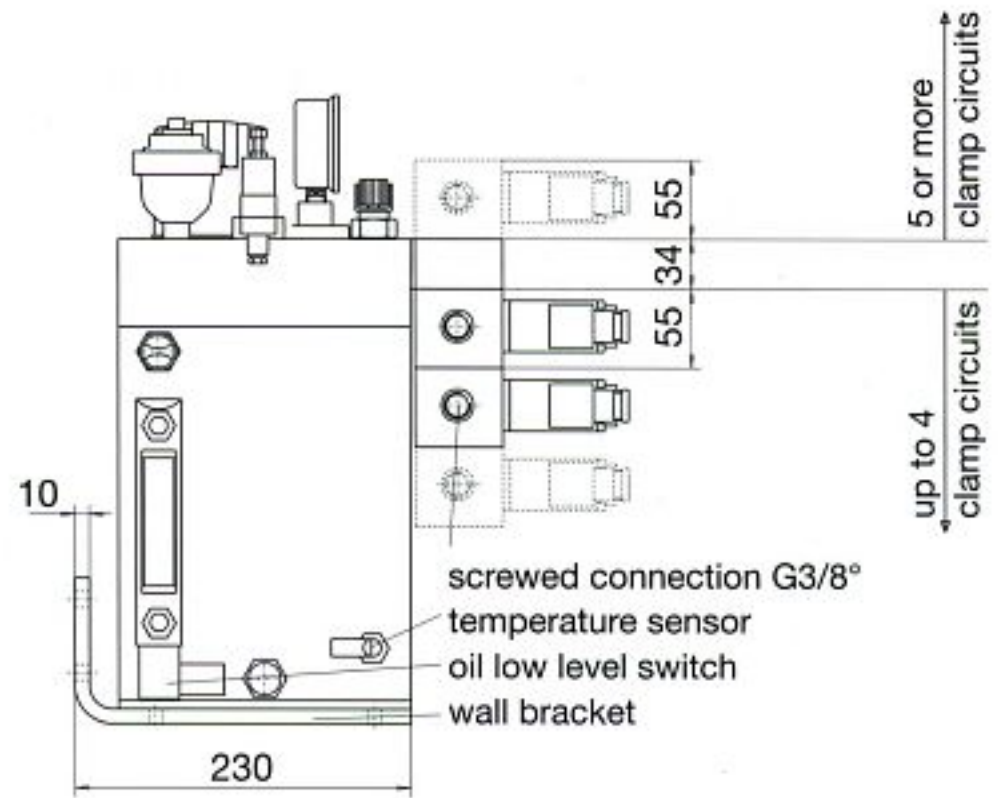
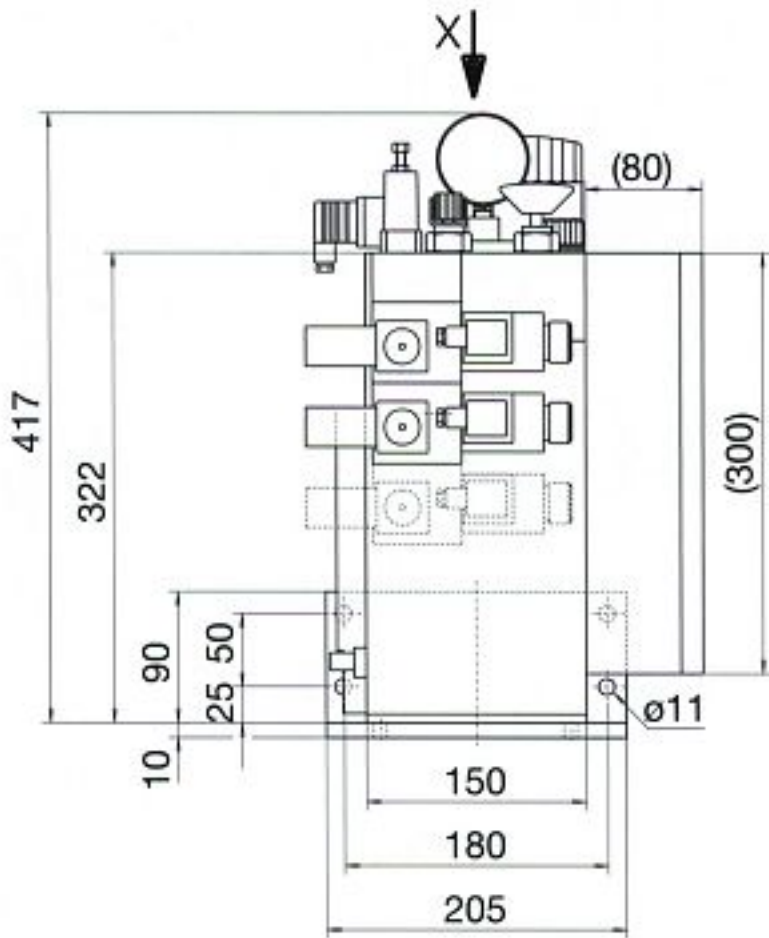

The dimensions indicated in () may change according to the range of the electrical control system.

	HAK 400	HAM 400
pump feed volume [l/min]	2	4
max. operating pressure [bars]	410	410
engine voltage	400V / 50Hz	400V / 50Hz
engine output [kW]	1,5	2,7
control voltage	24 V DC	24 V DC
tank volume [L]	5,5	5,5
effective volume [L]	2,5	2,5
screwed connection	G 3/8"	G 3/8"
hydraulic oil	DIN 51524	DIN 51524
oil viscosity	ISO VG 46	ISO VG 46
max. oil temperature [°C]	80	80
number of clamp circuits max.*	16	16
max. duration of operation with a full load [%]	10	10

